



CEILING RADIATION DAMPER FOR WOOD TRUSS CEILING ASSEMBLIES INSULATED REGISTER BOX • TOP INLET MODEL: 505RD



QUALIFICATIONS:

- **UL 263 CLASSIFIED CEILING RADIATION DAMPER. Category CABS. (File # 9660)**
1 hour rated for use in UL floor/ceiling design numbers L550/L574/L579 and roof/ceiling design numbers P531/P545 (Similar in construction to designs L521/L546 and P522).
- **Meets NFPA 90A requirements**

DESCRIPTION:

Ceiling dampers are designed to function as a heat barrier in air handling openings penetrating fire resistive membrane ceilings. The model 505RD has been especially designed and tested to provide protection and simple installation in specific UL design wood truss ceiling assemblies.

The 505RD assembly consists of a ceiling damper mounted in the round top inlet collar of an internally insulated sheet metal register box (boot) that accommodates a steel grille or register.

CONSTRUCTION:

1. UL listed fusible link, 212°F (100°C) standard.
2. Blades: 22 ga. (0.85) G60 roll-formed galvanized steel.
3. Blade Insulation: Non-asbestos UL Classified.
4. Damper frame: 22 ga. (0.85) G60 galvanized steel.
5. Internal Insulation: 1 1/2" (38) thick. R-Value 6.3.
6. Steel plenum: 28 ga. (0.47) min. with round connection collar.
7. UL Classified Class 0 or I Flexible Air Duct connection by others.
8. Plaster flange.
9. Steel grille / register (by others). Minimum depth for grille clearance is 2 1/2" (64).

OPTION:

Installation Support Angles. 26" (660) long.

- 2 @ 3/4" x 3/4" x 16 ga. (19 x 19 x 1.6) or
- 2 @ 1 1/2" x 1 1/2" x 22 ga. (38 x 38 x 0.85)

Installation Boot Rails. 26" (660) long.

- IBR 2 @ 1" x 24 ga. (25 x 0.70)

NOTE:

Building code and UL Classification require damper installation in accordance with manufacturer's instructions.

See Doc. RMP-CRDWTINST.

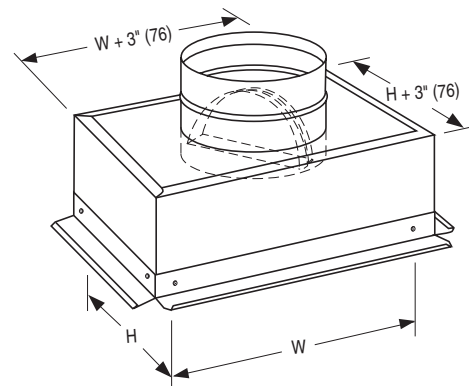
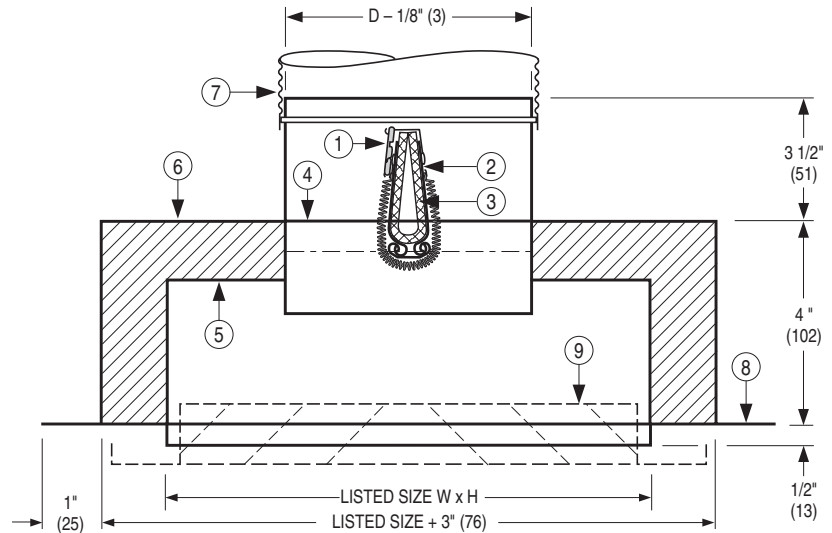

Dimensional Data:

Available Sizes	
W x H	Nom. Duct Size D
8 x 4 (203 x 102)	4", 5" (102, 127) dia.
10 x 4 (254 x 102)	4", 5", 6" (102, 127, 152) dia.
12 x 4 (305 x 152)	6", 7", 8" (152, 178, 203) dia.
8 x 6 (203 x 152)	6" (152) dia.
10 x 6 (254 x 152)	5", 6", 7" (127, 152, 178) dia.
12 x 6 (305 x 152)	6", 7", 8", 9" (152, 178, 203, 229) dia.
14 x 6 (356 x 152)	6", 7", 8", 9" (152, 178, 203, 229) dia.
8 x 8 (203 x 203)	5", 6" (127, 152) dia.
10 x 8 (254 x 203)	7", 8" (178, 203) dia.
12 x 8 (305 x 203)	7", 8" (178, 203) dia.
14 x 8 (356 x 203)	6", 7", 8", 9", 10" (152, 178, 203, 229, 254) dia.

W x H = Nominal Grille / Register Size

Dimensions are in inches (mm).

Date: 9-20-06 Dwg. 505RD