



**CEILING RADIATION DAMPER  
FOR WOOD TRUSS CEILING ASSEMBLIES.  
ETL CLASSIFIED UL263/E119.  
INSULATED REGISTER BOX • 45° INLET  
MODEL: 507RD**



**QUALIFICATIONS:**

- **ETL CLASSIFIED UL263/E119  
CEILING DAMPER.**
- **1 hour rated for use in floor/ceiling design numbers L550/  
L562/574/579/585/503/L563/L546/L521/L528/L530/L570/  
L586, and roof/ceiling design numbers P531/P538/P545/  
P522/P552/P533/P544/P548.**
- **Meets NFPA 90A requirements**

**DESCRIPTION:**

Ceiling dampers are designed to function as a heat barrier in air handling openings penetrating fire resistive membrane ceilings. The model series 507RD has been especially designed to provide protection and simple installation in specific design wood truss ceiling assemblies.

The 507RD assembly consists of a ceiling damper mounted in the round inlet collar of an internally insulated sheet metal register box (boot), that accommodates a steel grille or register.

**CONSTRUCTION:**

1. Listed fusible link, 212°F (100°C) standard.
2. Blades: 21 ga. G60 roll-formed galvanized steel.
3. Blade Insulation: Non-asbestos Classified.
4. Damper frame: 21 ga. G60 galvanized steel.
5. Internal insulation: 1 1/2" (38) thick. R-Value 6.3.
6. Steel plenum: 24 ga. max. with round connection collar
7. Classified Class 0 or I Flexible Air Duct connection by others.
8. Plaster flange: 1" wide x 1/2" deep.
9. Steel grille / register (by others). Minimum depth for grille clearance is 2 1/2".

**OPTION:**

1. Non-standard temp. listed fusible link □  
**165** 165°F (74°C)
- 2.. Installation Support Angles. 26" long.
  - 2 @ Standard boot rail
  - 2 @ 3/4" x 3/4" x 16 ga.
3. 1"x1" Plaster Flange
4. Available with R4, R6, & R8 ins.

**NOTE:**

Building code and Classification require damper installation in accordance with manufacturer's instructions.

Maximum collar opening 10 inches

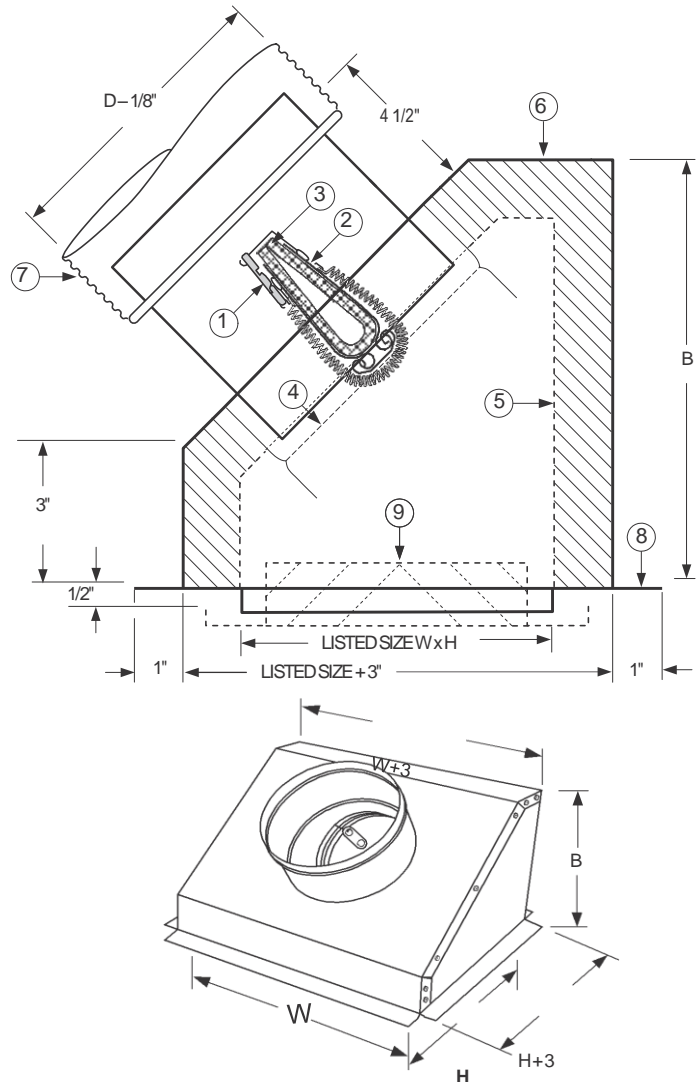

Dimensional Data: (Drywall Lip not Included)		B
Common Available Sizes		
W + H	APPX Nom. Duct Size D	
8 x 4	4", 5"	8 1/2
10 x 4	4", 5", 6"	8 1/2
12 x 4	6", 7", 8",	8 1/2
14 x 4	7"	8 1/2
8 x 6	6"	8 1/2
10 x 6	5", 6", 7",	8 1/2
12 x 6	6", 7"	8 1/2
14 x 6	6", 7", 8"	8 1/2
All others	Comfirm Size	11"

W x H = Nominal Grille / Register Size

Dimensions are in inches

**MODEL 507RD**